

SWINGER 3000

**THE VERSATILE, AFFORDABLE
ARTICULATED LOADER
AND TOOL CARRIER**

Photos may show optional equipment.

Lifts to 3,000 lbs. (SAE)

- Articulated — turns without skidding
- Easy on turf, terrain, sensitive surfaces
- Simple to operate — great visibility
- Accepts most skid steer attachments
- Has 25 gpm auxiliary hydraulic system
- 2-speed transmission for power/speed
- 80 hp John Deere Powertech diesel

Versatile lift and carry loader/tool carrier has the power, size and dependability to contribute to your bottom line. Husky 25 gpm auxiliary hydraulics give ample power for high demand attachments like hammers, tree spades, grapples, etc. Visibility is great and Swinger is easy to operate with steering wheel, single lever joy stick and “quick-attach” system.

Plus, there’s no rutting in turns. Allows operation on turf, landscape projects, nursery fields, new asphalt and other sensitive surfaces. Saves time otherwise spent in remediation and extends tire life compared to skid steer units.

Hydrostatic over mechanical drive is another Swinger feature — combines quick hydrostatic direction change with an easy maintenance mechanical drive (best of both systems).

Compare capacity, versatility and overall utility of a Swinger with any skid steer and you’ll see the value difference.



SPECIFICATIONS subject to change without notice

Engine: John Deere® Powertech® diesel, 80 hp.

Driveline: Low maintenance 4-wheel drive hydrostatic over mechanical with “short run” hydrostatics from the engine pump to the motor at the gear reducer. Dependable mechanical drive from the gear reducer to the wheels. Hydrostatic system has two speed forward transmission for extra power to the wheels when loading lime and performing other tough jobs.

Auxiliary Hydraulics: 25 gpm gear pump @ 2,500 rpm — powers high demand attachment tools. Separate throttle lever allows operator to select the speed of the bucket/boom functions and speed of the auxiliary attachments.

Articulation/oscillation: Articulation is 40 degrees either side of center for easy turning. Oscillation is 20 degrees (rear axle pivots over obstructions and helps maintain machine stability).

Axles: Dana series 80, rated at 11,000 lbs.

Operating capacity: 3,000 lbs., SAE rated.

Breakout force: 8,500 lbs.

Weight: 9,750 lbs.

Speed: 0-6 mph low range / 0-16 mph high range.

Fuel capacity: 15.8 U.S. gallons

Hydraulic reservoir: 16 U.S. gallons

Standard tires: 14" x 17.5, 8 ply rated

Dimensions:

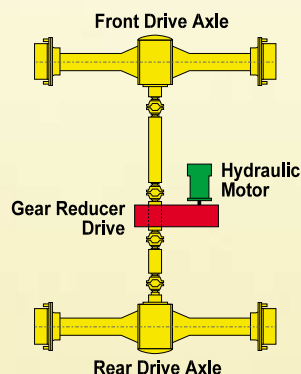
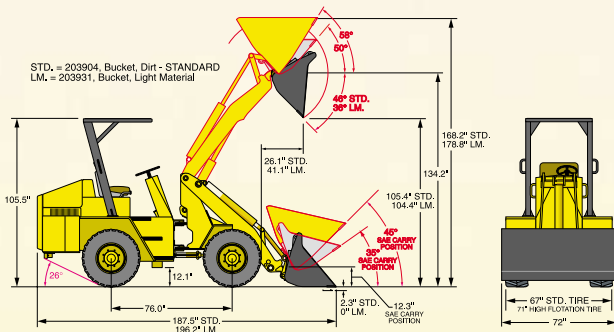

Swinger quality components include John Deere diesel engine, Dana axles and Eaton hydrostatic power. Swinger 3000 features short run hydrostatic over mechanical drive for easy operation and simple maintenance. Diagram shows hydrostatics (green motor) mounted to the mechanical gear reducer (red). It's simple mechanical drive from the gear reducer to the wheels (yellow).



Optional hard cab provides all-weather operator enclosure. ROPS guard is standard.



Steel plate lift arms, steel fenders and heavy duty lift cylinder and are standard equipment



Swinger drives like a car Hour meter Engine temp. Volt meter Oil press. Bucket level Joy stick Aux hyd. On/off



Quick-Attach system lets operator locate and lock attachments.



80 hp John Deere Powertech diesel supplies ample power for propulsion and attachments. Hood lifts, rear door opens and seat tilts for full engine access.

SWINGER

Loader Division of NMC-WOLLARD, Inc.
1125 Starr Ave.
Eau Claire, WI 54703
800-656-6867
Phone: 715-835-3151
Fax: 715-835-6625
E-mail: kbird@nmc-wollard.com
Website: www.nmc-wollard.com