

SWINGER

Model 1200

GSA Contract GS07F-5658A

- Compact loader/carrier
- Articulated — no turn ruts
- Small, nimble & powerful
- Lifts to 1,200 lbs. (SAE)
- Console control quick-attach



No-skid turns are easy on turf, sensitive surfaces

Swinger 1200 is a landscaper's dream with a compact loader/tool carrier — and a trailer full of job-critical attachments (center photo below). The ride-on power unit features auxiliary hydraulics, 32 hp diesel and no-rut articulated steering

Positive contributor to your bottom line. Does the work of a crew with one operator. Compact, articulated loader/carrier does not rut in turns. Operates where skid machines can't — saves time and money

Swinger Model 1200 is ideal for landscape, tree care and turf contractors who need a complete equipment system.



Swinger 1200 has dump height over 6-feet



Swinger Model 1200 loader/carrier is versatile... has front auxiliary hydraulics and control valve for quick-attach.

NMC-WOLLARD

Made in the U.S.A. by the Loader Division of NMC-WOLLARD, Inc.

SWINGER

MODEL 1200

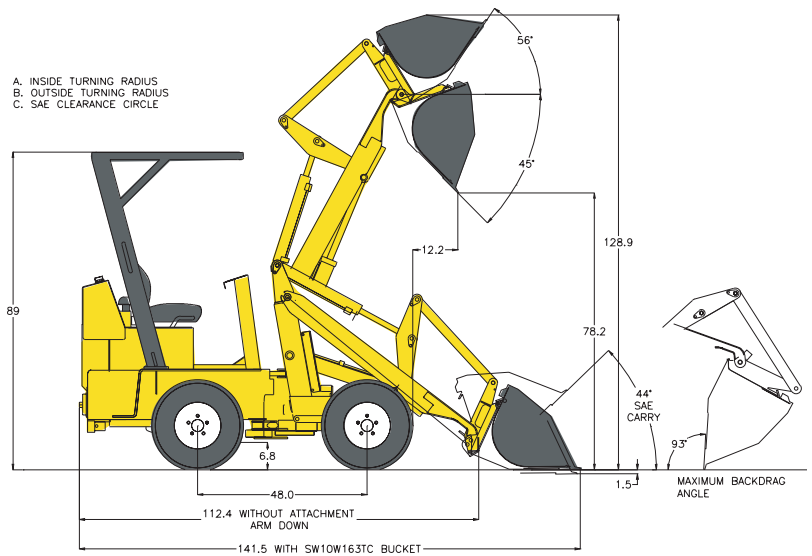
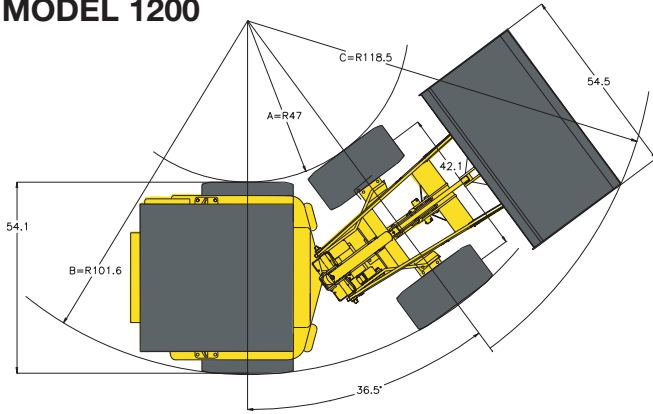

Dimensions & Data subject to change without notice

Weight (Std)	4,780 lbs. (2168 kg)
Max. Travel Speed.....	6.8 mph (10.9 kph)
Drawbar Pull.....	Consult Factory
Pin height.....	105.8" (2.69m)
Dump Height.....	78.2" (1.98)
Breakout Force.....	2,765 lbs (1254kg)
Operating Capacity.....	1,200 lbs (544kg)
Raise Time , Empty.....	4.72 Sec.
Lower Time, Empty.....	3.9 Sec.
Dump Time.....	2.43 Sec.
Aux. Hyd. Pressure.....	2,500 psi (172 bars)
Aux. Hydraulic Flow....	14.5 gpm (54.9 lpm)
Articulation Angle.....	±36.5°
Frame Oscillation.....	±6.2°

Engine: Kubota, V1505, 4-cylinder diesel, 35.5 hp. (26.5 kW), 91.5 cu. in. (1.5L)

Drive system: Eaton hydrostatic pump and motor coupled through a reduction gearbox to drive axles. Both axles are solid mounted and provide full-time 4x4. The independent front and rear frames oscillate ±6.2°.

Steering System: Center pivot and swing-link bearings allow frame sections to articulate ±36.5° for steering. Emergency back-up steering provided should engine fail.

Auxiliary Hydraulics: Gear pump system delivers 14.5 GPM flow at 2500 psi for steering and auxiliary equipment. Suction and return filters utilized to maintain system cleanliness. Oil cooler located in front of radiator. Hydraulic tank capacity is 6.3 gallons (24 Liters).

Cooling System: 4.2 qts. (4 liter) coolant capacity for engine-radiator system. 14 psi operating pressure. Radiator insulated from vibration. V-belt drive water pump and fan.

Brakes: Hydrodynamic four wheel service brakes. Parking brake is Orscheln lever and cable system with mechanical caliper and disc on driveline.

Tires: 26x12.00-12NHS Hi-floatation turf tire.

Electrical: 530 CCA 12V battery and 30 amp alternator with internal regulator. Loader starts only in neutral. All circuits protected with automotive fuses.

Instrumentation and Controls: Gauges include: voltmeter, coolant temperature, engine oil pressure, fuel level, and engine hour meter. Back-up alarm. Pedal for forward and reverse. Hand lever to set engine speed and parking brake. 14 inch diameter steering wheel for directional control. Valve has joystick for bucket control and single lever for auxiliary flow. Vinyl seat is adjustable forward and backward.

Frame: Heavy-duty precision aligned, 1-piece welded structures front and rear. Certified FOPS/ROPS overhead guard bolted to rear frame section.

Fuel Capacity: 6.5 gallons; 24.6 liters.

Corrosion Proofing: All frame and body surfaces are shot blasted, primed and painted with weather resistant paint. Standard bolts are SAE grade 5, zinc-phosphate coated to resist corrosion

Standard Equipment:

- Adjustable Seat
- Alternator, 30 amp
- Auxiliary Hydraulics, Front
- Back Up Alarm
- Coolant Temperature Gauge
- Disc Type Parking Brake
- Engine Hour Meter
- Engine, Kubota, 4 Cyl. Diesel
- Seat Belt
- Guard, Overhead ROPS
- Horn
- Hitch, Rear Receiver
- Hydraulic Valve, 4-Spool
- Oil Pressure Gauge
- Paint: Industrial high visibility yellow
- Single-Lever Loader Joy Stick
- Universal Tool Carrier w Hyd Power Latch

Voltmeter
Owner's Manual

Optional Equipment

- Adjustable Suspension Seat
- Bucket Level Indicator
- Bucket, Replaceable Cutting Edge
- Buckets: .33 - .85 cu. yd. (.25 - .65 cu. m.)
- Counter Weight Kits
- Flat Face Hydraulic Connectors
- Front Fenders
- Light Package
- Paint, Touch-Up, Yellow
- Pallet Fork Assembly (Many Sizes)
- Manuals (Parts and/or Shop)
- Spark Arrestor Muffler
- Steering Knob
- Tires, Bar Lug, 26x12.00-12
- Tires, Rimguard Filled
- Toothbar Attachment

SWINGER[®]
LOADERS
A DIVISION OF NMC-WOLLARD, INC.

2021 Truax Blvd, Eau Claire, WI 54703
Phone: 800-656-6867
Phone: 715-835-3151
Fax: 715-835-6625
Email: bsteingart@nmc-wollard.com
clanggaard@nmc-wollard.com
Website: www.nmc-wollard.com

4/05 -1M